

# TOP/ONE4

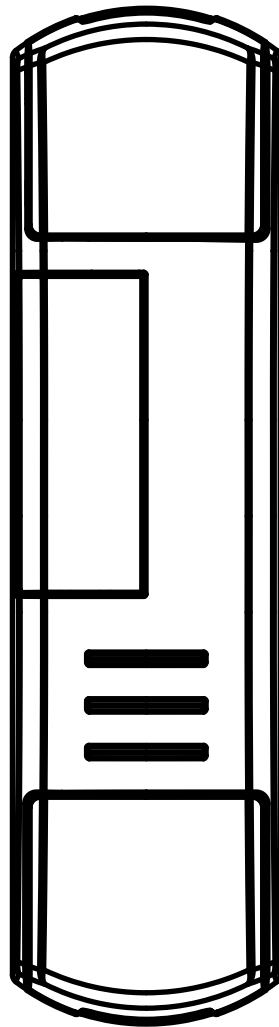

**Control unit for single-color live LEDs. Number of outputs that can be set.  
Power supply 12-24Vdc, Max 24A in total (2OUT= 8A each, 4 OUT=6A each)..  
433.92 MHz receiver for radio transmitters.  
Wi-Fi connection for "OneSmart" application**

# INDEX

1 - PRODUCT FEATURES	
1.1 - TECHNICAL DATA	Page 4
<hr/>	
2 - START UP OF THE CONTROL UNIT	Page 5
<hr/>	
3 - USE	Page 5
<hr/>	
4 - ELECTRICAL CONNECTIONS	
4.1 - TYPICAL CONNECTION	Page 6
4.2 - DETAILED CONNECTION DIAGRAM	Page 7
<hr/>	
5 - SETTING THE NUMBER OF SEPARATELY CONTROLLABLE OUTPUTS	Page 8
<hr/>	
6 - MANAGEMENT WITH REMOTE CONTROL	
6.1 - RADIO PROGRAMMING	Page 10
6.2 - DELETION OF REMOTE CONTROL	Page 11
<hr/>	
7 - MANAGEMENT FROM "ONESMART" APPLICATION	
7.1 - CONNECTION TO THE "ONESMART" APP WITH THE CONTROL UNIT	Page 12
<hr/>	
8 - CONTROL BY VOICE COMMANDS	
8.1 - CONNECTION TO "GOOGLE HOME"	Page 14
8.2 - CONNECTION TO "AMAZON ALEXA"	Page 16
<hr/>	
9 - ADVANCED PROGRAMS	
9.1 - CUSTOMIZING THE FUNCTION OF THE KEY OF THE TRANSMITTERS	Page 18
9.2 - SETTING A TIMER	Page 19
9.3 - STATUS OF THE LIGHT AFTER THE POWER SUPPLY CONNECTION	Page 20
9.4 - SETTING OF THE WIRED COMMAND INPUTS	Page 21
9.5 - FACTORY SETTINGS, RESET CONTROL UNIT	Page 22
<hr/>	
10 - FURTHER INFORMATIONS	
10.1 - CONNECTION PROBLEMS OF THE CONTROL UNIT TO THE ROUTER	Page 23
<hr/>	



# 1 - PRODUCT FEATURES

## 1.1 TECHNICAL DATA

Power supply (Input)	12 - 24 Vdc
LED type (Output)	Constant tension single color LED
Max power load (Output)	Max 8A per output if using only OUT1 and OUT2 (16A total) Max 6A per output, max 24A total
N° of programmable transmitters	30
RF receiver frequency	433.920MHz
WiFi frequency	2.4GHz
Protection rating	IP20
Working temperature	-20° +55°
Box dimensions	174x46x35 mm

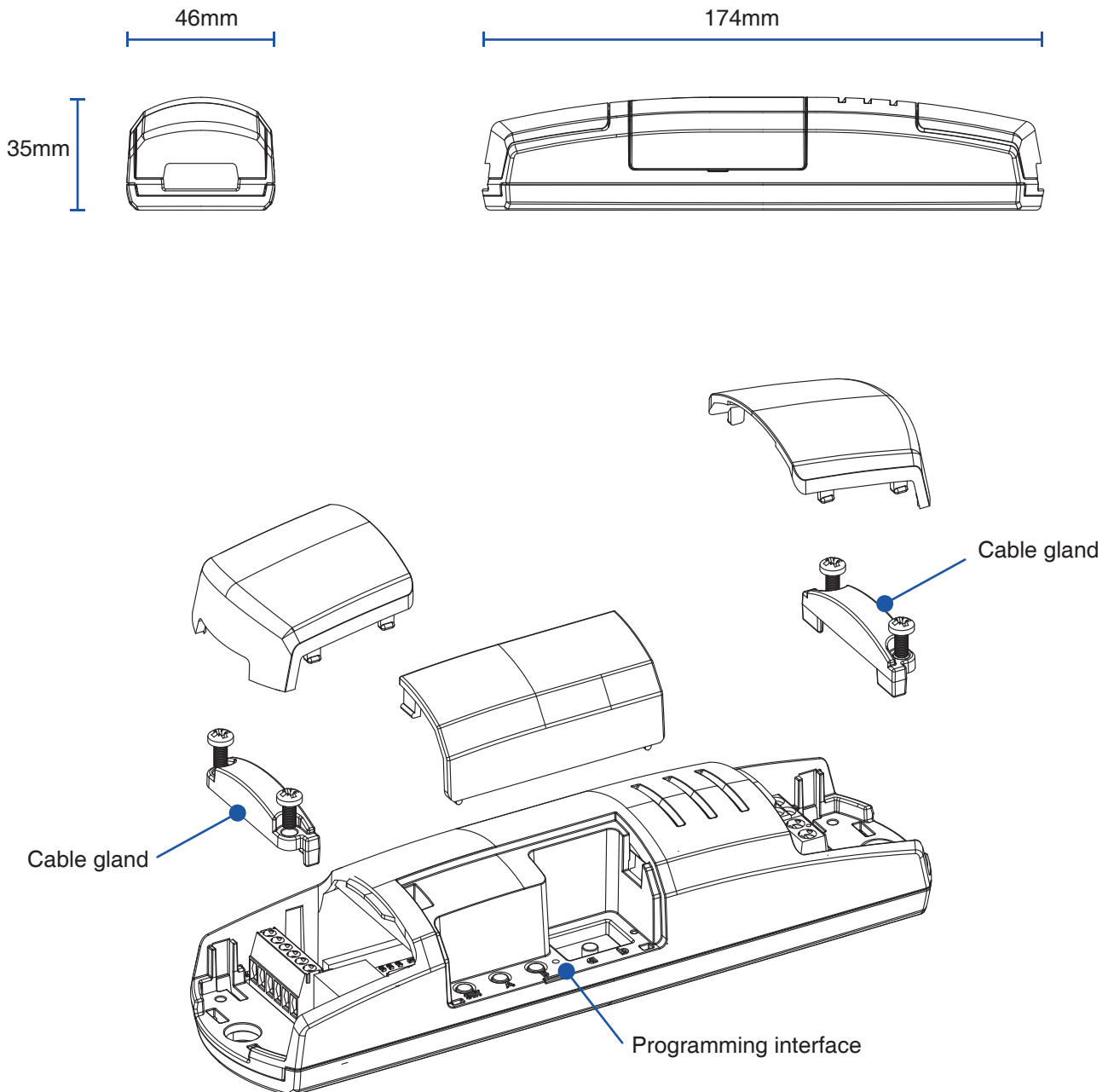

## 2 - START-UP OF THE CONTROL UNIT

Below is the guideline for the control unit start-up

### STEP 1 - CONNECTION

Make the electrical connections illustrated in paragraph 4.

#### ATTENTION:

If using two outputs: limit 8A per output, 16A total

If using 4 outputs: limit 6A per output, 24A total



### STEP 2 - SETTING THE NUMBER OF OUTPUTS

Set the number of outputs you want to control separately with the procedure in paragraph 5.

This control unit can in fact control the outputs in different ways, the available options are:

1. ONE LED LINE: All outputs controlled in a synchronized way
  2. TWO LED LINES: OUT1 and OUT3 controlled in a synchronized way and OUT2 and OUT4 controlled in a synchronized way
  3. THREE LED LINES: OUT1, OUT2 and OUT3 controlled separately. OUT4 not used
  4. FOUR LED LINES: OUT1, OUT2, OUT3 and OUT4 controlled separately.
- By default the control unit manages the 4 LED lines in a synchronized way



### STEP 3 - RADIO PROGRAMMING

Associate any radio controls with the procedure in paragraph 6.



### STEP 4 - PAIRING THE APP

If desired, associate the OneSmart WiFi application with the control panel using the procedure in paragraph 7.

#### ATTENTION:

To complete the WiFi association you need a 2.4GHz network with internet access.



### STEP 4 - CONFIGURING VOICE COMMANDS

If you want to configure the Google Home or Alexa applications for use with voice commands, see paragraph 8.



### THE SYSTEM IS CONFIGURED

## 3 - USE

After commissioning, the control unit is configured to control the connected LEDs in the following ways:

### WIRED BUTTONS COMMAND

Any connected wired buttons are already working. See paragraph 4 and paragraph 9.4 for available features.

### RADIO COMMAND

Once the remote control has been associated, see paragraph 6, refer to the user manual of the remote control itself for the functions.

### APP COMMAND

After completing the configuration in paragraph 7, you can use the OneSmart application to control the device.

NOTE: both the phone on which the application is installed and the device must be connected to a WiFi network with Internet access

### VOICE COMMAND

The system is compatible with Google and Alexa voice commands.

After completing the configuration in paragraph 8, you can control the device vocally through the Google Home or Amazon Alex application or with compatible voice assistants.

## 4 - CONNECTION DIAGRAMS

This control unit is able to drive 1, 2, 3 or 4 lines of single-color LED strips. By default, operation is set to control all OUTs in a synchronized manner. If you wish to separate the control of the LED lines, refer to paragraph 5.

### RECOMMENDATIONS

- Installation must be carried out only by professional technicians in accordance with the applicable electrical and safety regulations.
- All connections shall be operated without electrical voltage.
- Use proper cables.
- Don't cut the antenna
- Provide in the power line with an appropriate disconnection device
- Dispose of waste materials in full compliance with local law.
- Do not exceed the specified load limits and use correctly protected power supplies.

### 4.1 TYPE CONNECTION

The typical connection of the control unit is illustrated graphically below.

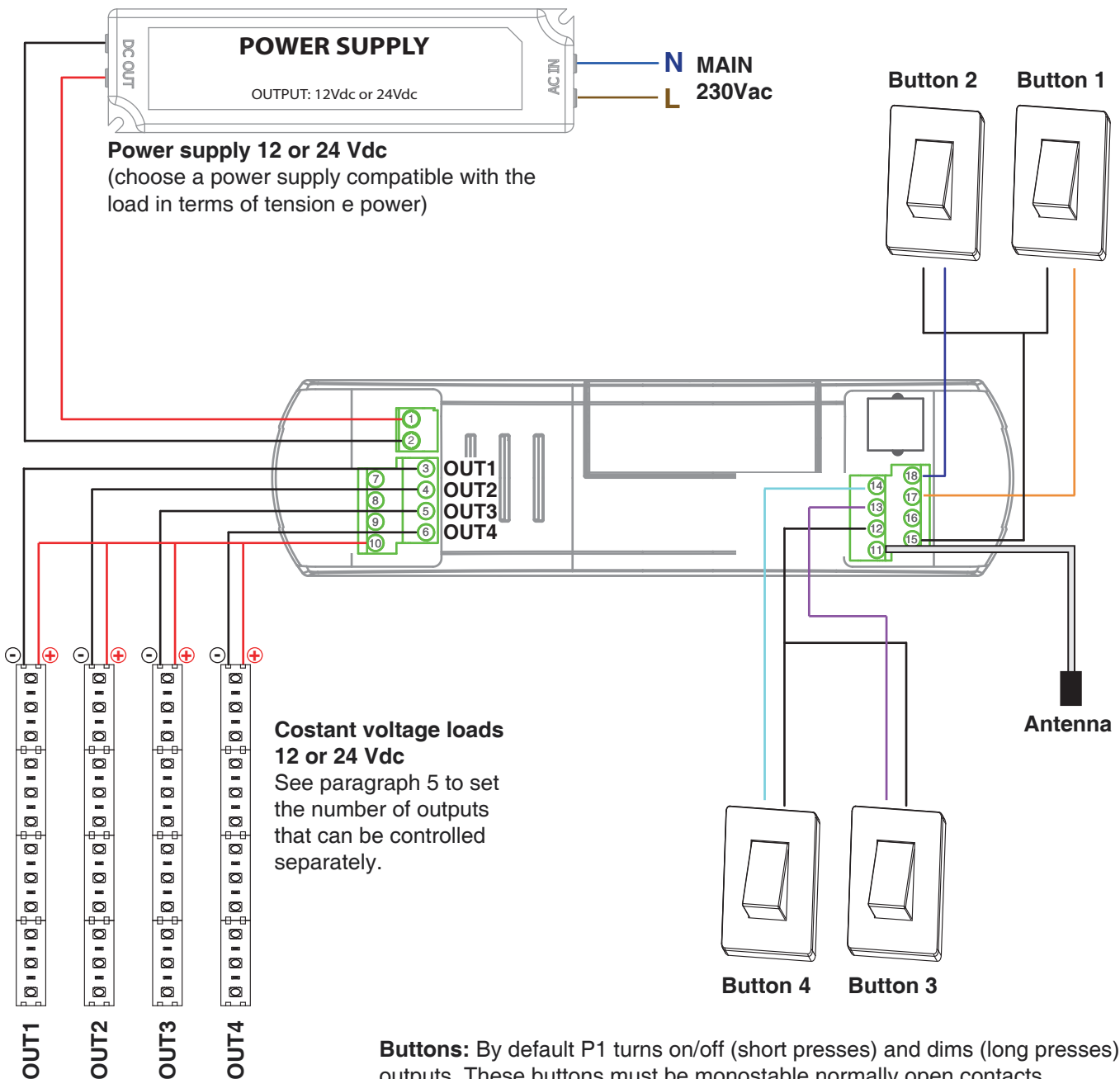

**Buttons:** By default P1 turns on/off (short presses) and dims (long presses) all outputs. These buttons must be monostable normally open contacts. P3 is designed for a bistable contact with the function: closed contact = all OUTs on, open contact = all OUTs = off. See paragraph 9.4 to change the functions.

## 4.2 DETAILED CONNECTION DIAGRAM

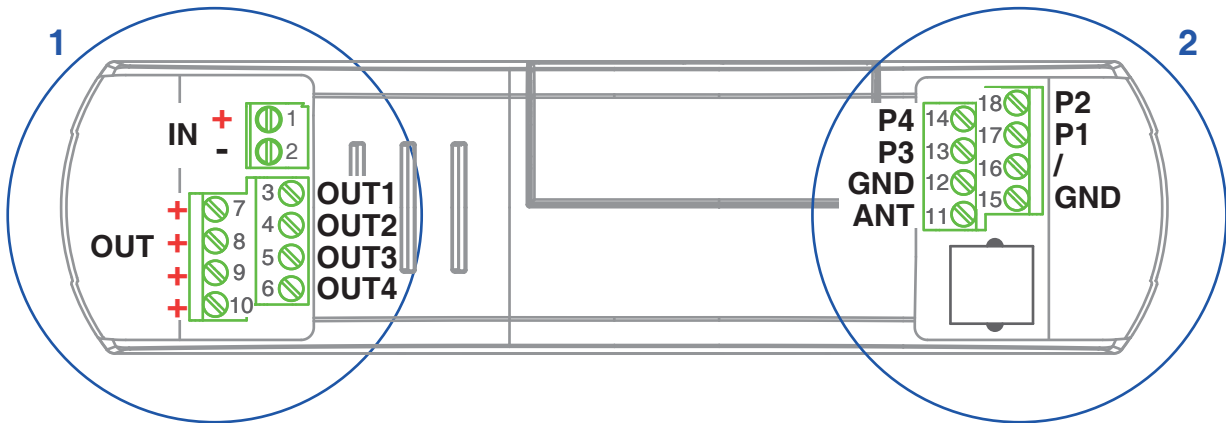

### 1 - POWER SUPPLY AND OUTPUTS

#### Outputs (-)

See paragraph 5 to set the number of outputs that can be controlled separately.

OUT1 (-)  
OUT2 (-)  
OUT3 (-)  
OUT4 (-)

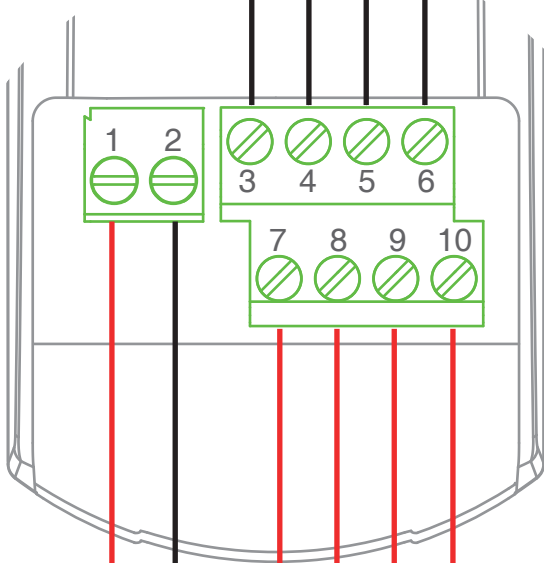

**Power supply**  
12 or 24 Vdc  
(choose a power supply suited to the connected load in terms of voltage and power)

**Common (+) of the load**  
Terminals 1, 7, 8, 9 and 10 are equivalent to each other

### 2 - CONTROL AND ANTENNA INPUTS

#### NOTES:

- The GND terminals are equivalent to each other
- The default function can be modified, see paragraph 9.4

**GND**= Button common

**P3**= Input 3 for NC contacts. Closed contact = all OUTs on, open contact = all OUTs off.

**P4**= Input 4 for NO button. Default: no function

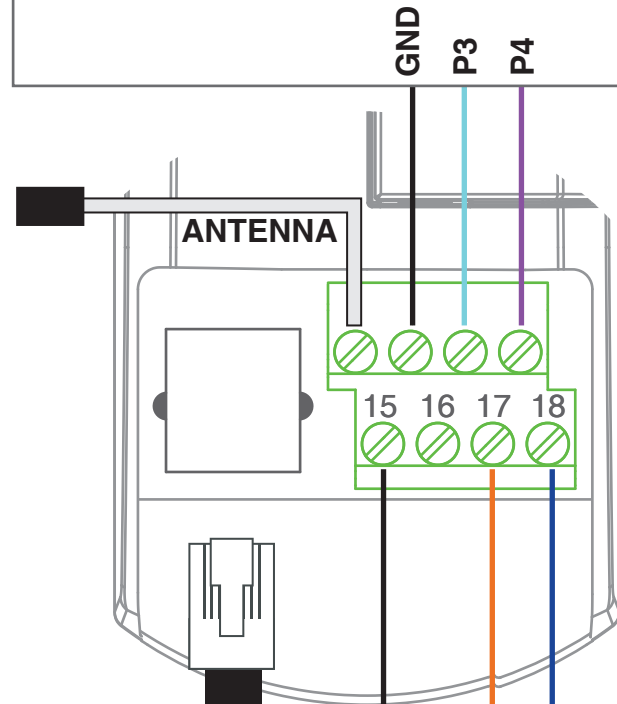

**EXTENDER \***  
Provision for power extender connection with RJ11

**GND**= Button common

**P1**= Input 1.

Default: On/Off (short press) and Dim Up/Down (long press) of all connected outputs

**P2**= Input 2.

Default: Off of all connected outputs

\* **EXTENDER** If it is necessary to increase the power of the connectable load, it is possible to purchase a “slave” control unit that exactly repeats the actions of the “master” control unit, ensuring load synchronization. The “master/slave” connection occurs via an RJ11 cable.

## 5 - SETTING THE NUMBER OF SEPARATELY CONTROLLABLE OUTPUTS

Default: all outputs synchronized

Changing the number of separately controllable outputs modifies:

- The behavior (synchronized or separate switching on) of the connected outputs
- The radio association procedure: it will be possible to program transmitters on a number of outputs equal to those set
- The application interface: a number of controllable outputs equal to those set will be displayed

### ATTENTION:

- Every time the following procedure is carried out, the control unit deletes all the programming carried out (radio programming, input settings...)
- This procedure does not change the operation of the connected wired buttons for which there is a specific procedure. See paragraph 9.4.

### DESCRIPTION

The available options are:

1. ALL OUTPUTS CONTROLLED IN A SYNCHRONIZED WAY (VIA RADIO AND VIA WIFI)
2. OUT1 AND OUT3 CONTROLLED IN A SYNCHRONIZED MODE AND OUT2 AND OUT4 CONTROLLED IN A SYNCHRONIZED MODE (VIA RADIO AND VIA WIFI)
3. OUT1, OUT2 AND OUT3 CONTROLLED SEPARATELY (VIA RADIO AND VIA WIFI). OUT4 not used.
4. OUT1, OUT2, OUT3 AND OUT4 CONTROLLED SEPARATELY (VIA RADIO AND VIA WIFI)

## PROCEDURE

### STEP 1

Press and hold the P2 key:  
The LED turns on cyclically in red, green, blue and yellow.  
Each colour corresponds to a setting:

Colour	Number of separately controllable outputs
Red	1
Green	2
Blue	3
Yellow	4

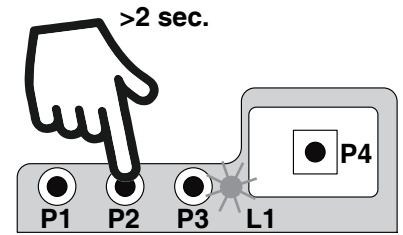

**ACTION:** Hold down P2  
**LED:** Turns on red, green, blue, yellow cyclically.

### STEP 2

Release the key corresponding to the colour associated with the desired setting.

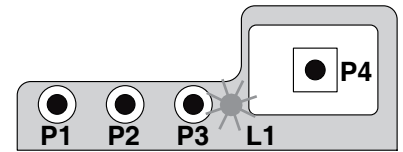

**ACTION:** Release the key  
**LED:** Stays fixed on

### STEP 3

Make a short press of the P2 key to confirm the setting.  
The LED makes a number of flashes equal to the number of LED lines set.

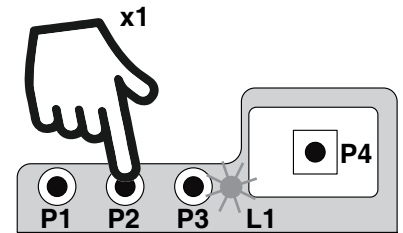

**ACTION:** Short press P2 button  
**LED:** It flashes as many times as the set value

## 6 - MANAGEMENT WITH REMOTE CONTROL

This procedure lets you programme/delete compatible multifunctional or generic (Wireless bus) transmitters.

### Multifunctional transmitters:

With multifunctional transmitters the transmitter control modes depend on the model used.

Refer to the transmitter manual, to the paragraph entitled “commands sent by the transmitter”, bearing in mind that: this is a dimmer device.

### Generic (wireless bus) transmitters:

With generic transmitters, the function of the button is:

SHORT PRESS: On/Off

LONG PRESS: dimmer Up/Down

The functions of the generic transmitters can be customized using the procedure in paragraph 9.1.

### 6.1 - RADIO PROGRAMMING

This procedure lets you programme compatible multifunctional or generic transmitters.

Depending on the number of lines of LED strip lights set with the procedure in paragraph 5, the remote control can be programmed for the active outputs.

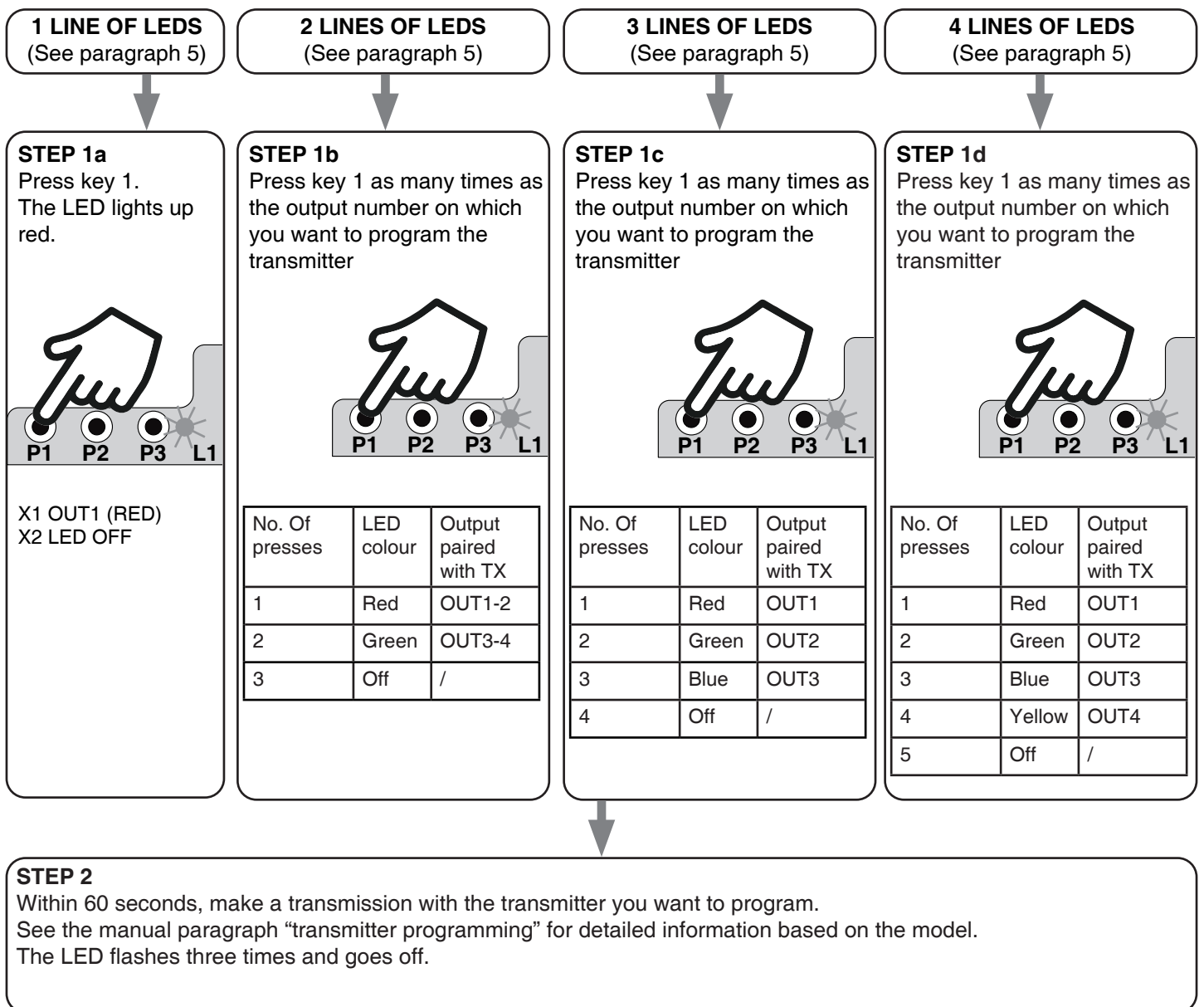

## 6.2 - DELETION OF REMOTE CONTROL

These procedures let you delete from the memory transmitters that have already been programmed.

### STEP 1

Hold the receiver button P1 down (about 5 seconds.) until the LED begins to Flash.

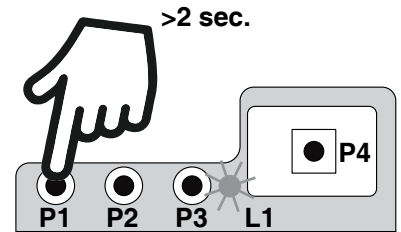

**ACTION:** Hold button P1 down  
**LED:** Flashes red

**DELETION OF SINGLE  
TRANSMITTER**

**DELETION OF ALL  
TRANSMITTER SAVED**

### STEP 2a

Within 10 seconds make a transmission with the transmitter that you want to delete.  
The LED flashes quickly and turns off.

### STEP 2B

Within 10 seconds press the button P1 on the receiver for a short time to confirm the deletion of all transmitters.  
The LED starts flashing quickly and turns off.

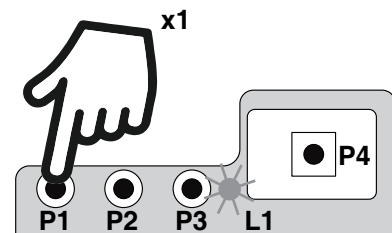

**ACTION:** Short press of P1  
**LED:** Flashes red quickly and turns off

## 7 - MANAGEMENT FROM “ONESMART” APPLICATION

This procedure allows you to connect the electronic control unit to a WiFi network to be controlled via application both with local and remote operation.

The application also allows you to create automations, i.e. automatic actions (linked for example to sunset or time) that will be managed by the Cloud.

To configure the system you need:

- A 2.4GHz WiFi network with Internet access
- A phone with the OneSmart application downloaded connected to the WiFi network to which the electronic control unit will then also be connected

Once the system is configured, the control panel must always have a WiFi network available and the devices used to control the system must also be connected to the Internet, not necessarily to the same WiFi network.

### 7.1 - CONNECTION TO THE “ONESMART” APP WITH THE CONTROL UNIT

The procedure on the following page allows you to make the first association of the device to the application.

If you cannot access the programming interface in the box, you can activate WiFi listening in step 3 of the procedure on the following page with the following methods:

#### WIRED INPUTS

- Make continuous short presses on wired input 1 (x10) until the LEDs connected to the outputs emit flashes
- Complete the procedure

#### RADIO CONTROL

- If you have a compatible remote control, send the WiFi association radio command (refer to the specific remote control manual).
- The LEDs connected to the outputs emit flashes
- Complete the procedure

#### SHARING DEVICES

For sharing the device, the simplest solution for sharing devices is to create an email dedicated to the OneSmart application. After pairing the devices for the first time with the first phone, to use the system from other phones simply download the OneSmart app and log in with the same credentials.

Alternatively, you can share the single device with a OneSmart account through the options within the device screen or a “home” in the “home management” menu in the OneSmart “Mi” window.

#### APP CONTROL SCREENS

According to the settings in paragraph 5, only the set number of LED lines will be visible on the device control screen.

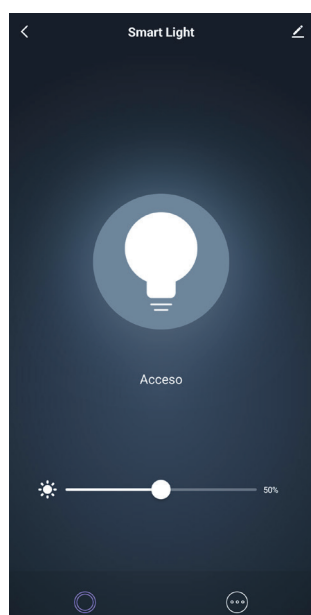

Schermata 1OUT

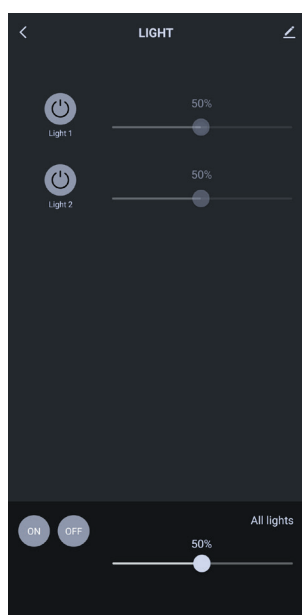

Schermata 2OUT

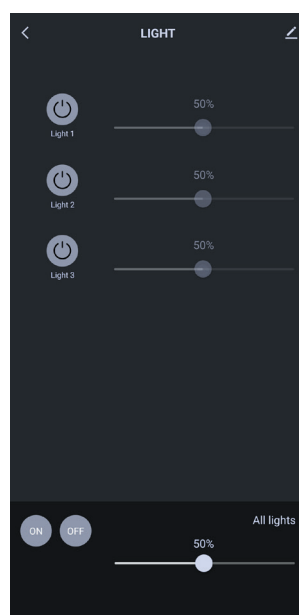

Schermata 3OUT

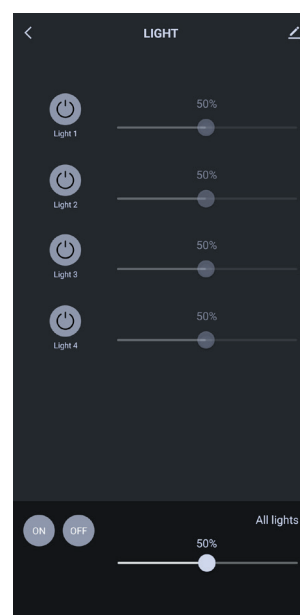

Schermata 4OUT

## PROCEDURE

### STEP 1

Download the “OneSmart” application from the store and after launching it, follow the procedure for creating an account. You will need to enter a valid email (to which a verification code will be sent) and a password.

The account is necessary to be able to register the devices in the Cloud and therefore be able to control them remotely or start scenarios automatically.



### STEP 2

Before proceeding, make sure you have enabled Bluetooth on your phone and that you are connected to the WiFi network to which you want to associate the control unit.

Therefore, to start the procedure for adding a device, press the “+” icon and then the “add device” icon (1) from the home screen.

On the next screen, select the “add” icon that appears in the “Discovering devices” window (2). This window only appears if your phone has Bluetooth enabled on your phone.

Alternatively, press on the “Smart Device” icon (3) but this procedure may not be successful depending on the router you are trying to connect to.

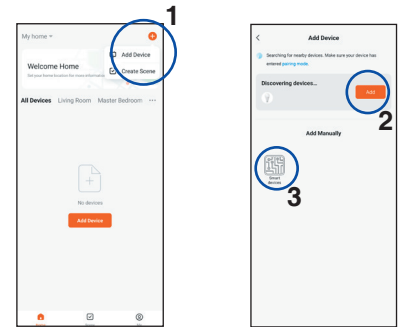

### STEP 3

Long press the P4 button.

Hold down the P4 button until the LED lights up blue.

After a few seconds the LED on the control unit begins to make series of one flashes to indicate that WiF programming has been entered.

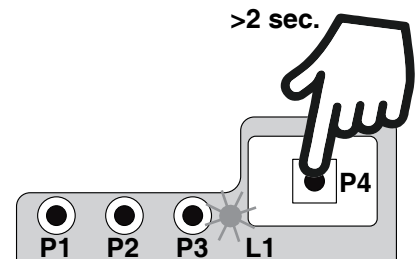

### STEP 4

The WiFi network to which the phone is connected and which will be used to connect the control panel will then be proposed.

Enter the network password (4)

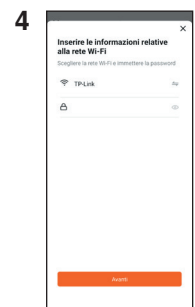

### STEP 5

The device will now configure itself automatically. The blue LED on the board signals the progress of the setting:

Series of one flash = the control unit is ready for configuration

Series of two flashes = the control panel is trying to connect to the network

Series of 4 flashes = the control unit has connected correctly

Depending on the outcome of the procedure, the LED will turn off after three minutes.

Once the procedure is completed, the device will be visible on the application's home screen.

For connection problems, see paragraph 10.1

## 8 - CONTROL BY VOICE COMMANDS

With this procedure you can associate a “OneSmart” account with a Google or Alexa account to use voice commands.

### 8.1 - CONNECTION TO “GOOGLE HOME”

#### PROCEDURE

**WARNING:** before proceeding with this procedure, you must have set up the “OneSmart” account, see paragraph 7.

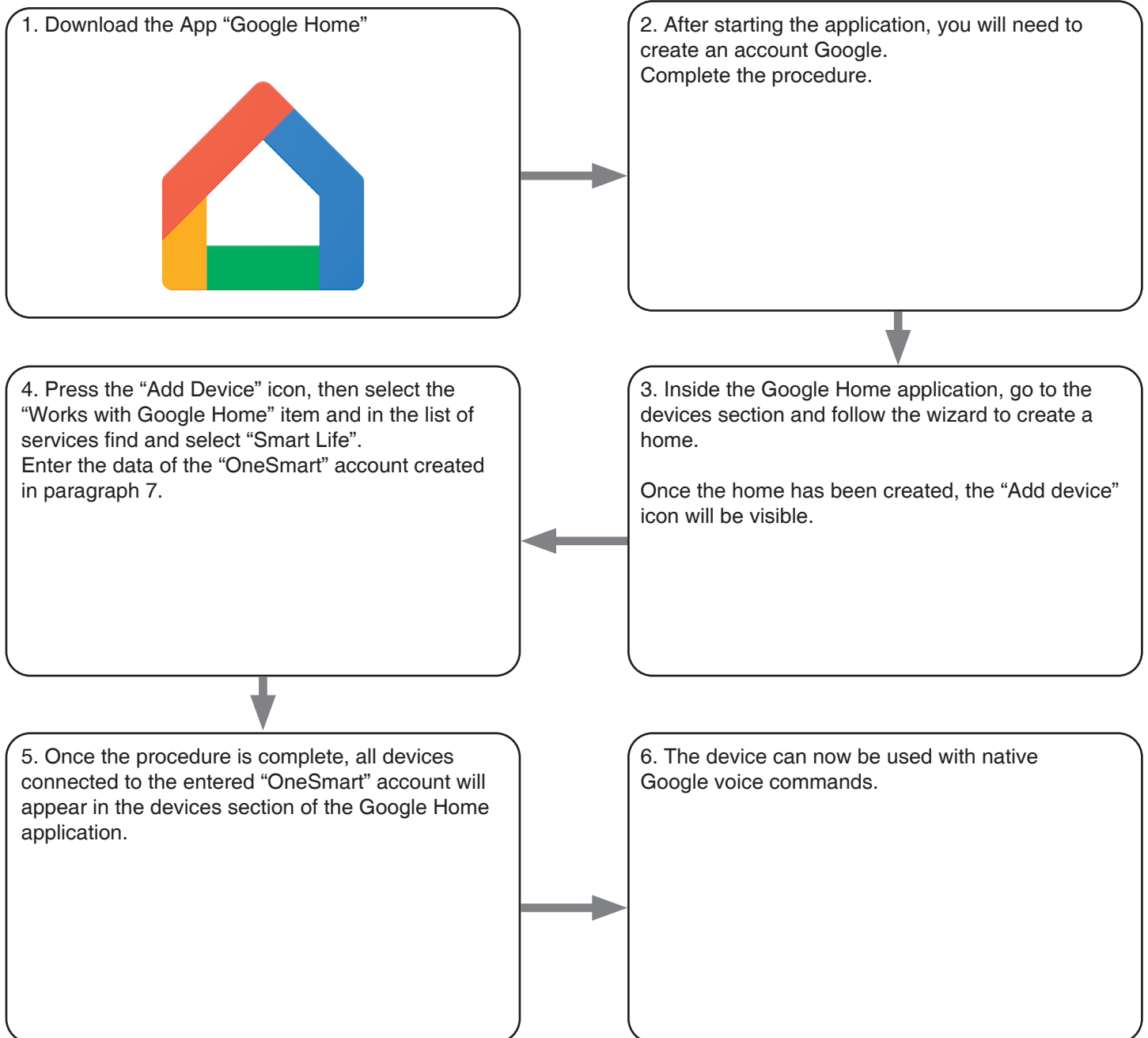

#### NOTES:

If you add other devices to your OneSmart application, they will automatically be added to the Google Home page. If devices are not added automatically, disconnect and reconnect your account from step 3 of this procedure from Google Home.

## **USE OF “GOOGLE HOME”**

### **HOW TO SEND VOICE COMMANDS**

Using your Android mobile phone (or tablet), voice commands can already be sent via the native assistant.

By using an Apple device, you can use the microphone within the Google Home application. If you want to add a Google voice recognition device, follow the procedures to match it to the house you created and then they will be associated with the lights.

### **VOICE COMMAND LIST**

Google provides native commands compatible with light-type devices (example: turn on, 30%, minimum...).

To control the LEDs, simply send these commands followed by the device name that appears in the Google Home application list. It is possible to change the names of each light within the Google Home application in the options of each device.

If there are multiple devices, voice commands can also be addressed to all the lights present (example: turn off all the lights)

Through the use of automations within the app, it is also possible to create customized commands.

## 8.2 - CONNECTION TO “AMAZON ALEXA”

### PROCEDURE

**WARNING:** before proceeding with this procedure, you must have set up the “OneSmart” account, see paragraph 7.

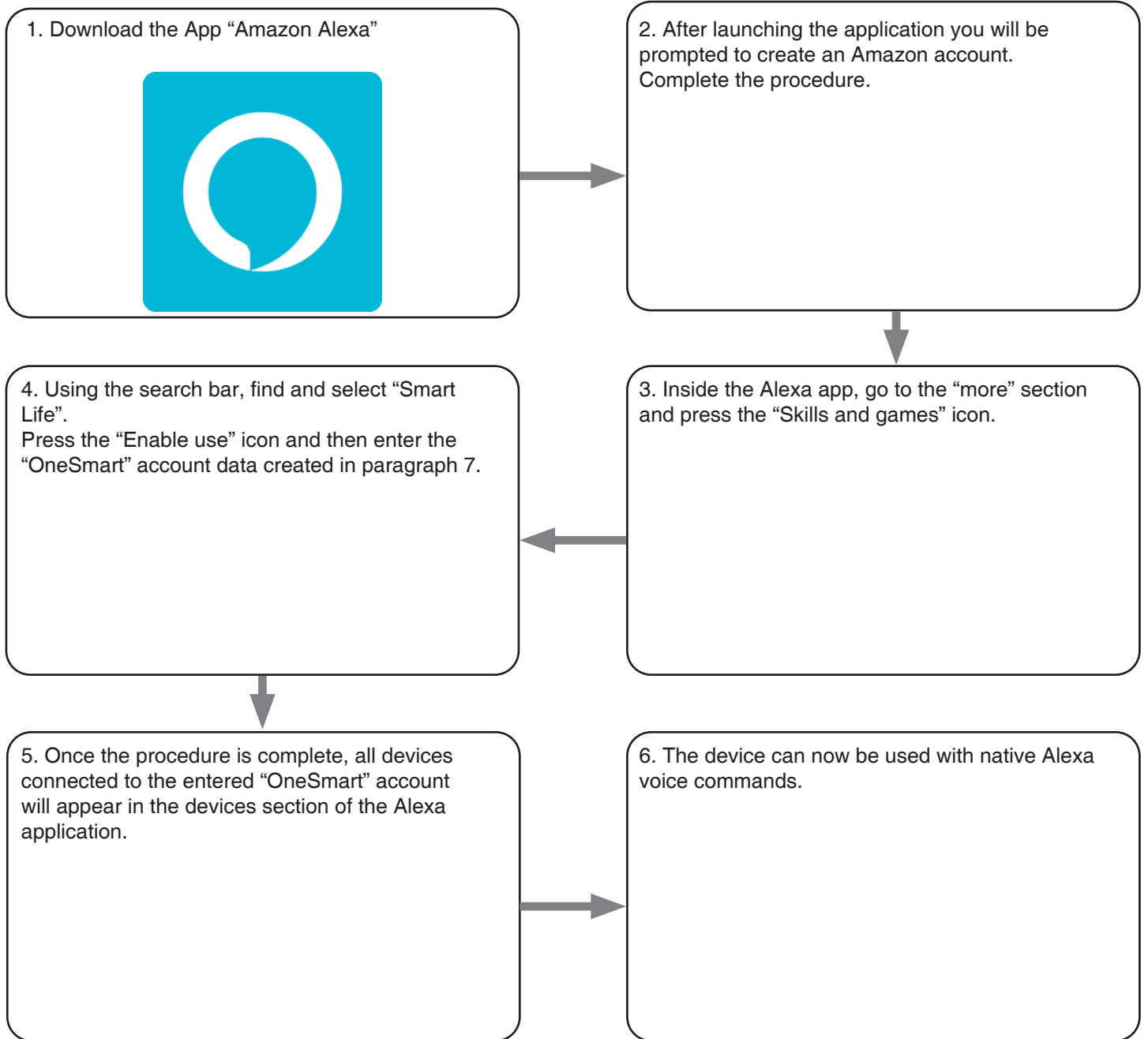

### NOTES:

If you add other devices to your OneSmart application, they will automatically be added.

If devices are not added automatically, disconnect and reconnect your account from step 3 of this procedure from Google Home.

## **USE OF “GOOGLE HOME”**

### **HOW TO SEND VOICE COMMANDS**

It is already possible to send voice commands via your mobile phone using the native assistant present within the Amazon Alexa application.

If you want to add an Alexa voice recognition device, follow the procedures to pair them with the house created and later they will also already be associated with the lights.

### **VOICE COMMAND LIST**

Alexa provides native commands compatible with light-type devices (example: turn on, 30%, minimum...).

To control the LEDs, simply send these commands followed by the device name that appears in the Alexa application list.

It is possible to change the names of each light within the Alexa application in the options of each device.

If there are multiple devices, voice commands can also be addressed to all the lights present (example: turn off all the lights)

Through the use of automations within the app, it is also possible to create customized commands.

## 9 - ADVANCED PROGRAMS

### 9.1 - CUSTOMIZING THE FUNCTION OF THE KEY OF THE “WIRELESS BUS” TYPE TRANSMITTERS

With the following procedure it is possible to set a customized function for the transmitter button of the “wireless bus” family.

#### Insights of settable functions

Function 5 - Memo

Each time the key is pressed briefly, the load flashes to signal that the current state of the light has been memorized for future switching on.

If the key is pressed when the light is off, storage is deactivated and the light will turn on again at the last value set, as by default.

#### PROCEDURE

##### STEP 1

Press the P1 key a number of times equal to the output on which you want to associate the transmitter. The LED lights up according to the following table. Based on the setting in paragraph 5, 1, 2, 3 or 4 outputs will be available.

N° pressure	Led color	Output associated to the tx
1	Red	OUT1
2	Green	OUT2
3	Blue	OUT3
4	Yellow	OUT4
5	Off	/

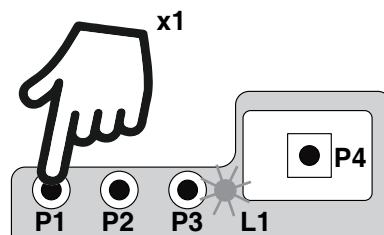

**ACTION:** Short presses of P1 key  
**LED:** Turns on

##### STEP 2

Short press the button P2 on the receiver and count the number of flashes emitted by the LED.

NUMBER OF FLASHES	FUNCTION
1	On
2	Off
3	Short press: On Long press: Dimmer Up
4	Short press: Off Long press: Dimmer Down
5	Memo

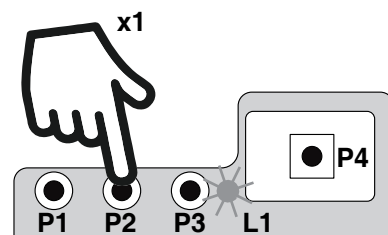

**ACTION:** Short press of P2 key  
**LED:** It flashes

##### STEP 3

Short press the P2 key while the flashing corresponds to the desired function to end the count. The LED lights up steadily.

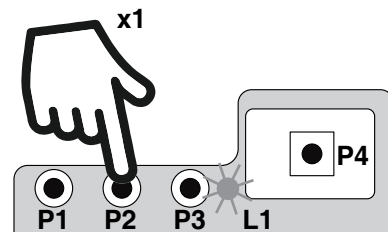

**ACTION:** Short press of key 2 while flashing **LED:** Lights up red

##### STEP 4

Within 60 seconds, make a transmission with the transmitter you want to program. See the paragraph “transmitter programming” for detailed information based on the model.

The LED flashes three times and goes off.

**ACTION:** Sending a command from a transmitter **LED:** Flashes and turns off

## 9.2 - SETTING A TIMER

Default: 18 hours

With the following procedure it is possible to introduce a timer to switch off the light automatically. All commands restart the time count, with the exception of the following which will immediately switch off the light: short press of the wired input with Off function, off command from transmitter, application or voice.

### PROCEDURE

#### STEP 1

Keep the P3 key pressed, the LED turns on cyclically in green, blue and purple. Release when the led is green.

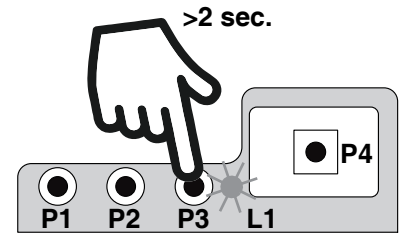

**ACTION:** Hold down the P3 button  
**LED:** turns on cyclically in green, blue and purple

#### STEP 2

Short press the button P3 on the receiver and count the number of flashes emitted by the LED.

NUMBER OF FLASHES	FUNCTION
1	No timing
2	30 seconds
3	1 minute
4	2 minute
5	5 minute
6	15 minute
7	30 minute
8	1 hour
9	2 hours
10	3 hours
11	8 hours
12	12 hours
13	18 hours

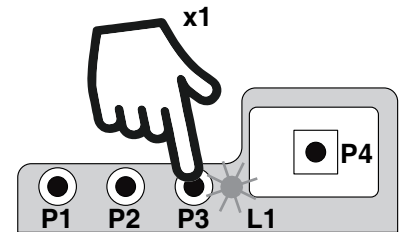

**ACTION:** Short press of P3 key  
**LED:** It flashes

#### STEP 3

Short press the P3 key while the flashing corresponds to the desired function to end the count. The LED lights up steadily.

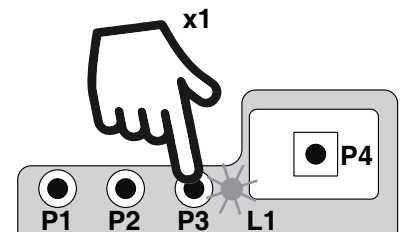

**ACTION:** Short press of P3 key  
**LED:** It flashes as many times as the set value

### 9.3 - STATUS OF THE LIGHT AFTER THE POWER SUPPLY CONNECTION

Default: last value before power failure

This procedure sets the state of the light when the control unit is powered (useful for example if the control unit is powered by a main switch or by a clock upstream).

#### PROCEDURE

##### STEP 1

If you want to memorize a light state when powering the board, set the LEDs to the desired value with radio, wired or app commands.

##### STEP 2

Keep the P3 key pressed, the LED turns on cyclically green, blue and purple. Release when the led is blue.

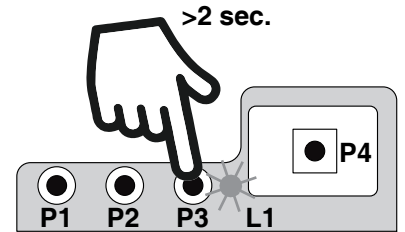

**ACTION:** Hold down the P3 button

**LED:** turns on cyclically in green, blue and purple. Release when the led is blue.

**FIXED LIGHT STATUS**

**LAST STATUS MEMORY FUNCTION**

##### STEP 3a

Short press the P1 button to save the light status at the board power supply equal to the current LED status.

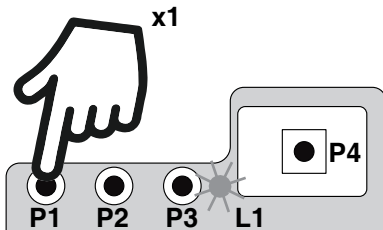

**ACTION:** Short press of P1 key  
**LED:** It flashes quickly and turns off

##### STEP 3b

Press the P2 button briefly to enable the memo function when powering the board (restarting at the value prior to the blackout).

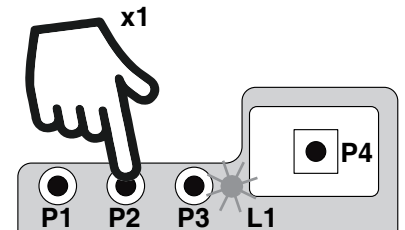

**ACTION:** Short press of P2 key  
**LED:** It flashes slowly and turns off

## 9.4 - SETTING OF THE WIRED COMMAND INPUTS

Default: mode 1 (In1: On/Off and dimmer of all led lines)

With the following procedure it is possible to modify the function of the wired command inputs connected to the board. The function of the inputs is independent of the number of LED lines set, any commands addressed to LED lines that are not present will not be performed.

### PROCEDURE

#### STEP 1

Keep the P3 key pressed, the LED turns on cyclically green, blue and purple.  
Release when the led is purple.

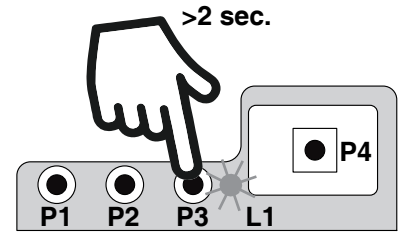

**ACTION:** Hold down the P3 button

**LED:** turns on cyclically in green, blue and purple. Release when the led is purple.

#### STEP 2

Short press the button P3 on the receiver and count the number of flashes emitted by the LED.

FLASHES NUMBER	SETTING MODE	INPUT 1 FUNCTION	INPUT 2 FUNCTION	INPUT 3 FUNCTION	INPUT 4 FUNCTION
1	Mode 1	On/Off (short press) and dimmer (long press) of all Outs	Off of all Outs	Closed contact = all Outs on Open contact = all Outs = off.	Not used
2	Mode 2	On (short press) and dimmer Up (long press) of all Outs	Off (short press) and dimmer Down (long press) of all Outs	Closed contact = all Outs on Open contact = all Outs = off.	Not used
3	Mode 3	On/Off (short press) and dimmer (long press) of OUT 1	On/Off (short press) and dimmer (long press) of OUT2	On/Off (short press) and dimmer (long press) of OUT3	On/Off (short press) and dimmer (long press) of OUT4
4	Mode 4	On (short press) and dimmer Up (long press) of OUT1 and 3	Off (short press) and dimmer Down (long press) of OUT1 and 3	On (short press) and dimmer Up (long press) of OUT2 and 4	Off (short press) and dimmer Down (long press) of OUT2 and 4

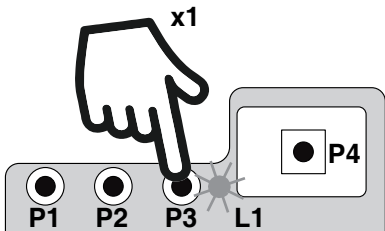

**ACTION:** Short press of P3 key  
**LED:** It flashes

#### STEP 3

Short press the P3 key while the flashing corresponds to the desired function to end the count.

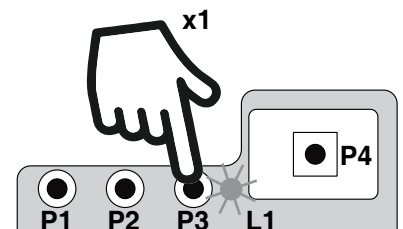

**ACTION:** Short press of P3 key  
**LED:** It flashes as many times as the set value

## 9.5 - FACTORY SETTINGS, RESET CONTROL UNIT

The following procedure restores the control unit to the factory parameters.

### PROCEDURE:

#### STEP 1

Press and hold the P1 key until the red LED flashes.

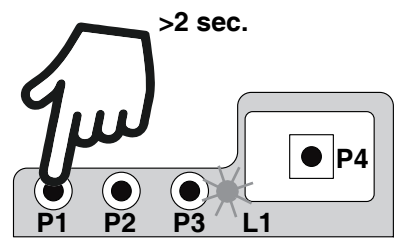

**ACTION:** Hold down the P1 button  
**LED:** red LED flashes.



#### STEP 2

Short press the P2 key.  
The red LED flashes quickly and goes off.

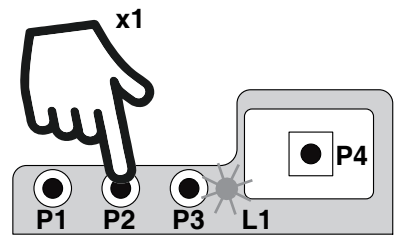

**ACTION:** Short press of P2 key  
**LED:** red LED flashes quickly and goes off.

## 10 - FURTHER INFORMATIONS

### 10.1 - CONNECTION PROBLEMS OF THE CONTROL UNIT TO THE ROUTER

If you have problems to connecting the card to the router, we recommend:

#### **PRELIMINARY CHECKS**

- Check that the network to which the control panel is being associated is 2.4GHz (not 5GHz)
- The mobile phone used for association must be connected to the same network to which the card is to be connected
- Check that the WiFi network password is correct

#### **OPERATIONS**

- Close the application and redo the procedure from step 1
- If possible try with a different mobile phone

If this does not resolve the problem, there may be some settings in the router that make the network incompatible with the control system.

To check and change these settings it is necessary to access the router configuration, based on the make/model this takes place either from a connected PC or from a manufacturer's application, usually the information is present on a label on the router itself.

The parameters to check/set are

#### **WIFI FREQUENCY**

Some routers generate a network that automatically uses a 2.4GHz or 5GHz frequency based on the device you are connecting to.

In the configuration phase, the device is the mobile phone which could use the 5GHz frequency preventing communication with the control unit.

It is therefore necessary to access the router settings and force the 2.4GHz network or alternatively create two networks, recognizable by the assigned name, at 2.4GHz and 5GHz.

During the association phase, pay attention to connect the mobile phone to the 2.4GHz network.

#### **WIRELESS SECURITY**

Some security protocols set in routers are not compatible with the system.

Within the router settings check and if necessary set

#### **WIRELESS SECURITY:**

**SECURITY TYPE: WPA2**

**ENCRYPTION TYPE: AES**



MNLTOP/ONE4ENV1.0

**Nexta Tech**

company brand of Team srl  
via G.Oberdan 90, 33074  
Fontanafredda (PN) - Italy  
Ph. +39 0434 998682  
Email: [info@nexta-tech.com](mailto:info@nexta-tech.com)  
Web: [www.nexta-tech.com](http://www.nexta-tech.com)