

# MCU-PUSH

*Radio iwireless interface for devices with dimmable input push dim*

NEXTA  
T E C H

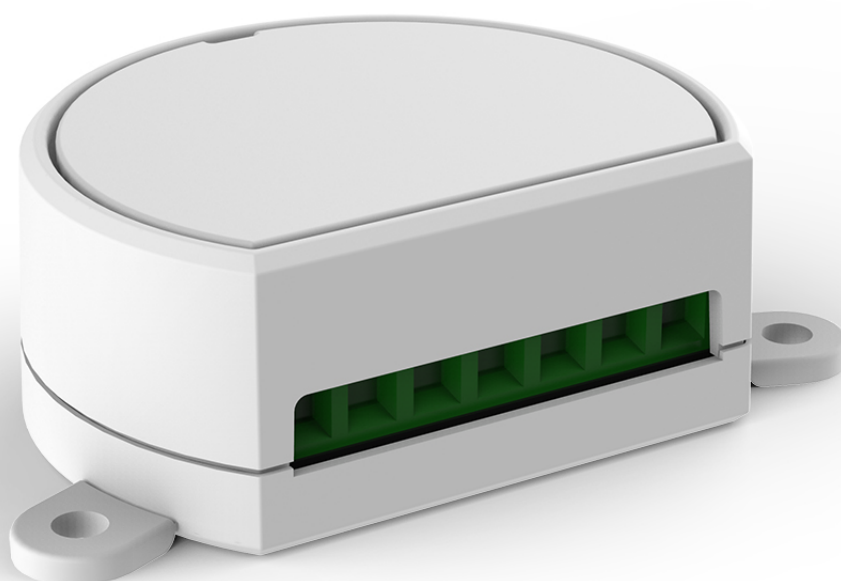

---

## INDEX

### 1 - PRODUCT FEATURES

- 1.1 - TECHNICAL DATA
- 1.2 - DESCRIPTION

### 2 - ELECTRICAL CONNECTIONS

- 2.1 - SCHEMA DI COLLEGAMENTO
- 2.2 - INSTALLATION EXAMPLE

### 3 - USE OF THE CONTROL UNIT

- 3.1 - USE VIA RADIO
- 3.2 - USE VIA WIRE

### 4 - RADIO PROGRAMMING

- 4.1 - RADIO PROGRAMMING OF MULTIFUNCTIONAL AND GENERIC TRANSMITTERS
- 4.2 - DELETION OF RADIO

# WARNINGS

- Installation must be carried out only by qualified technicians in compliance with the electrical and safety standards in force.
- All connections must be made with the power turned off.
- Use suitable cables.
- Do not cut through the aerial (see figure 1.1b)
- A suitably sized disconnection device must be set up on the electric power line that supplies the product.
- Disposal of waste materials must fully respect local standards.

## 1 PRODUCT FEATURES

### 1.1 TECHNICAL DATA

Power supply	Mains 120-240 Vac
Outputs	1 potential-free contact max 5A
Number of programmable transmitters	100
Radio frequency	433.920MHz ISM
Protection rating	IP20
Operating temperature	-20 +55 °C
Dimensions	52x43x21 mm

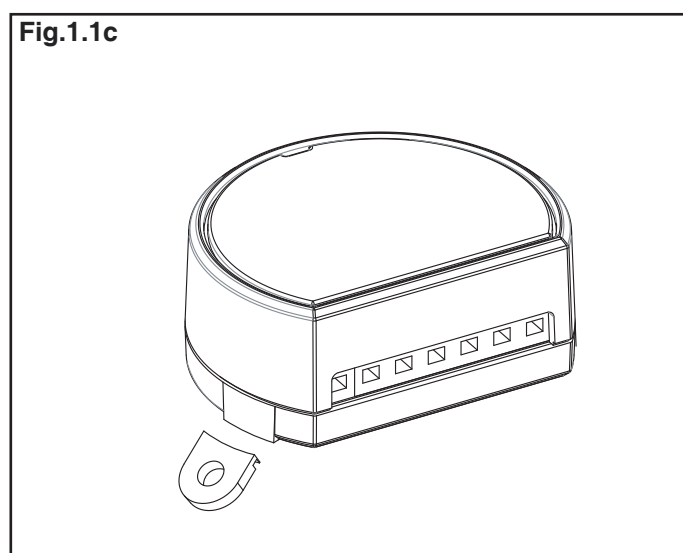
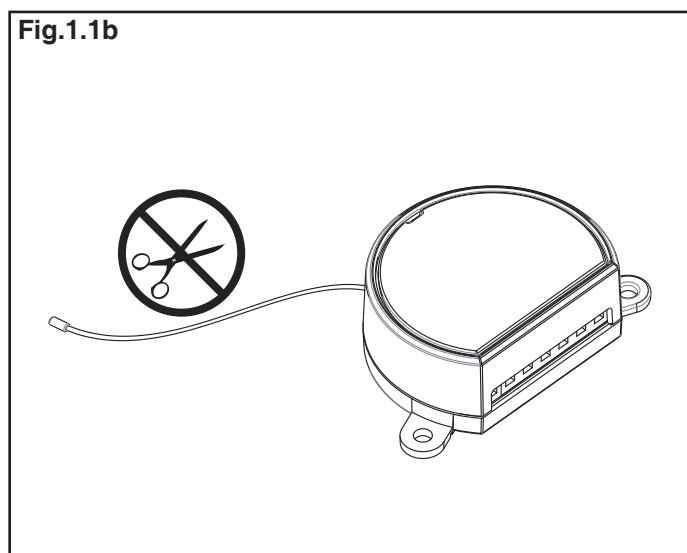
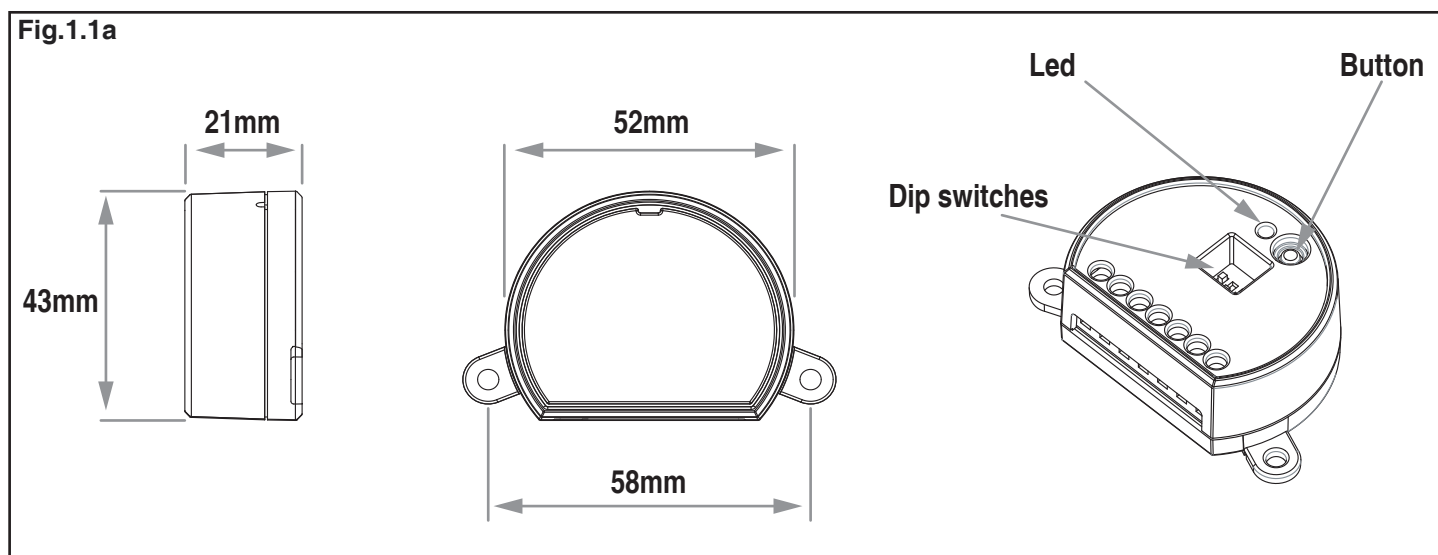

## 1.2 DESCRIPTION

MCU-PUSH is a miniaturised electronic control unit for managing a device via radio and wire.

The ISM (industrial, scientific and medical) radio frequency band guarantees a long range, even through walls and ceilings.

Simple programming with dip-switches, reduced dimensions with breakable tabs (fig. 1.1c) for fixing with screws (fig. 1.2a) or for insertion into connection boxes up to 55 mm in diameter (fig. 1.2b, 1.2c, 1.2d, 1.2e).

Fig.1.2a

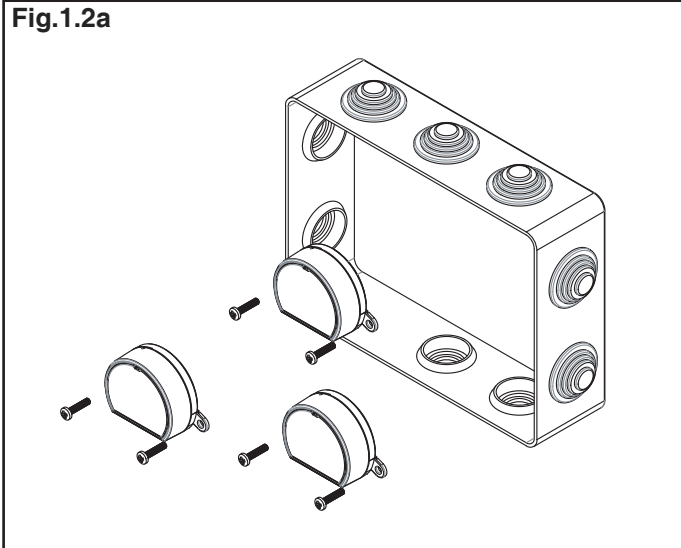

Fig.1.2b

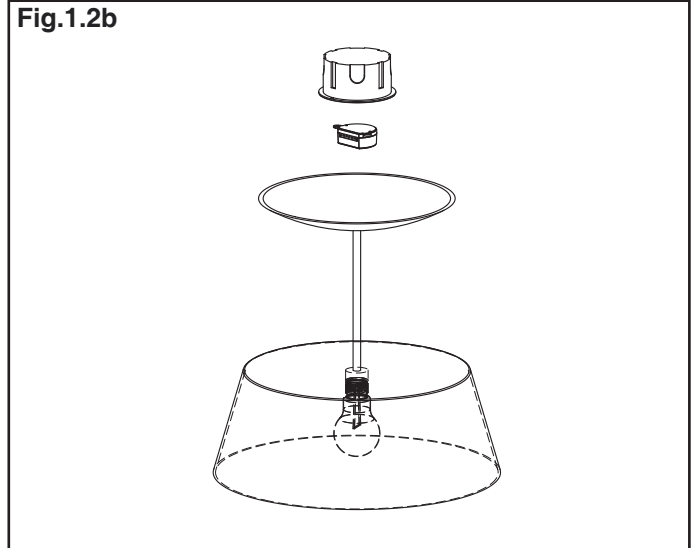

Fig.1.2c

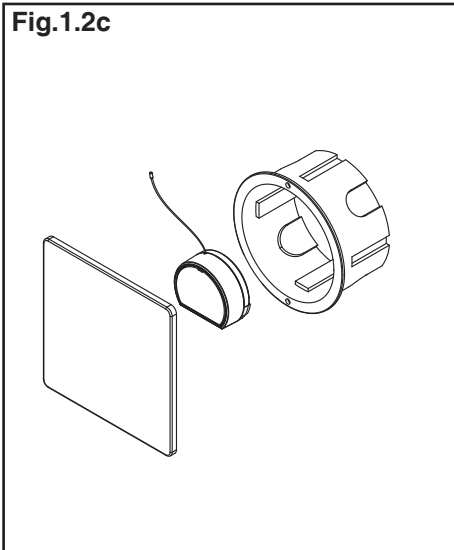

Fig.1.2d

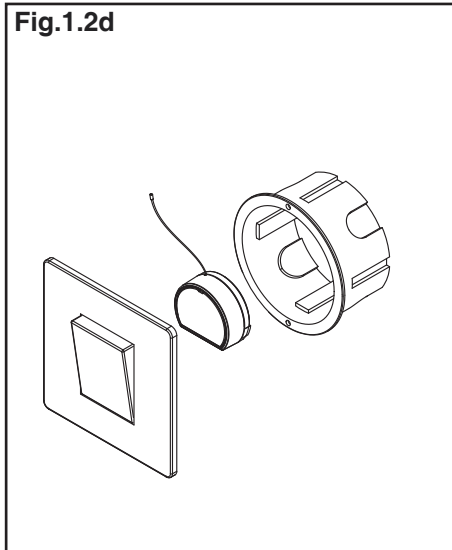

Fig.1.2e

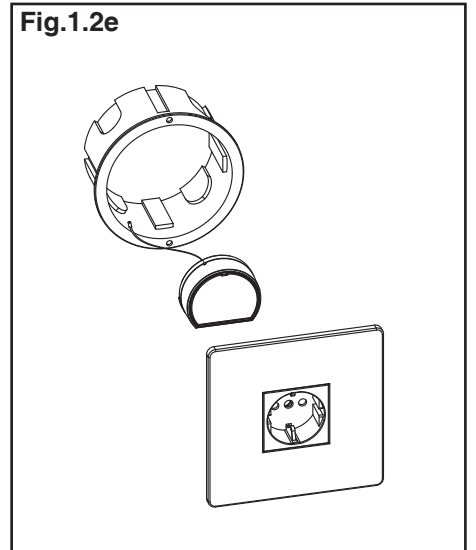
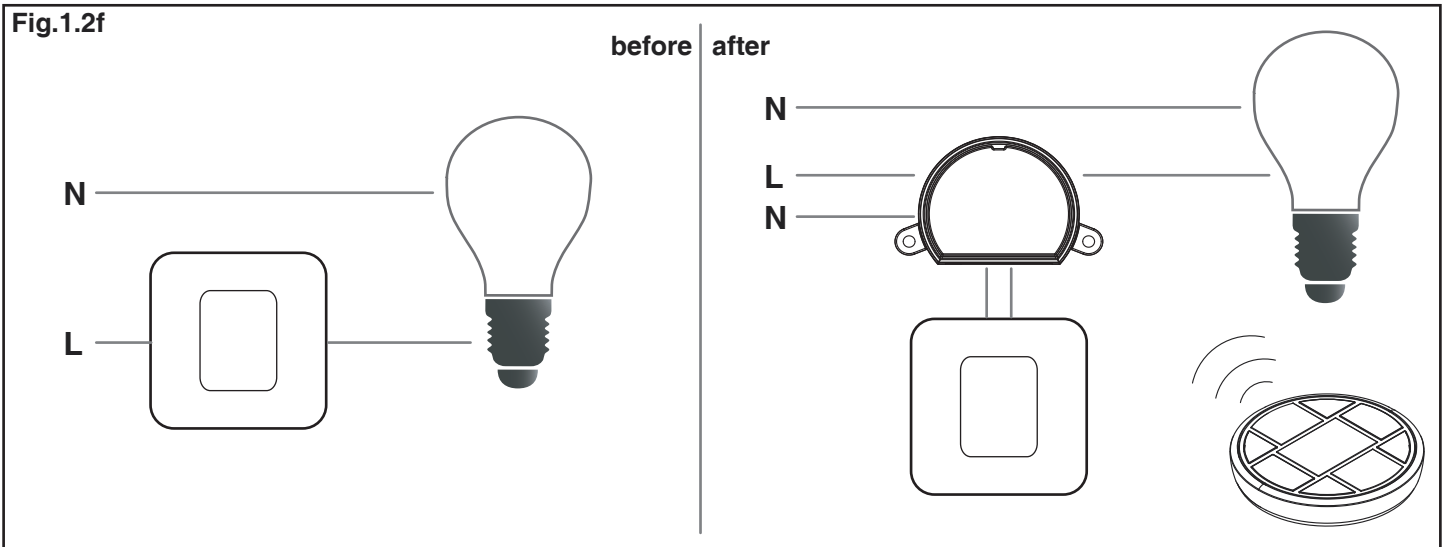

Fig.1.2f



## 2 ELECTRICAL CONNECTION

### 2.1 CONNECTION DIAGRAM

The following connection lets you control device with potential-free dimmable contact

Fig.2.1

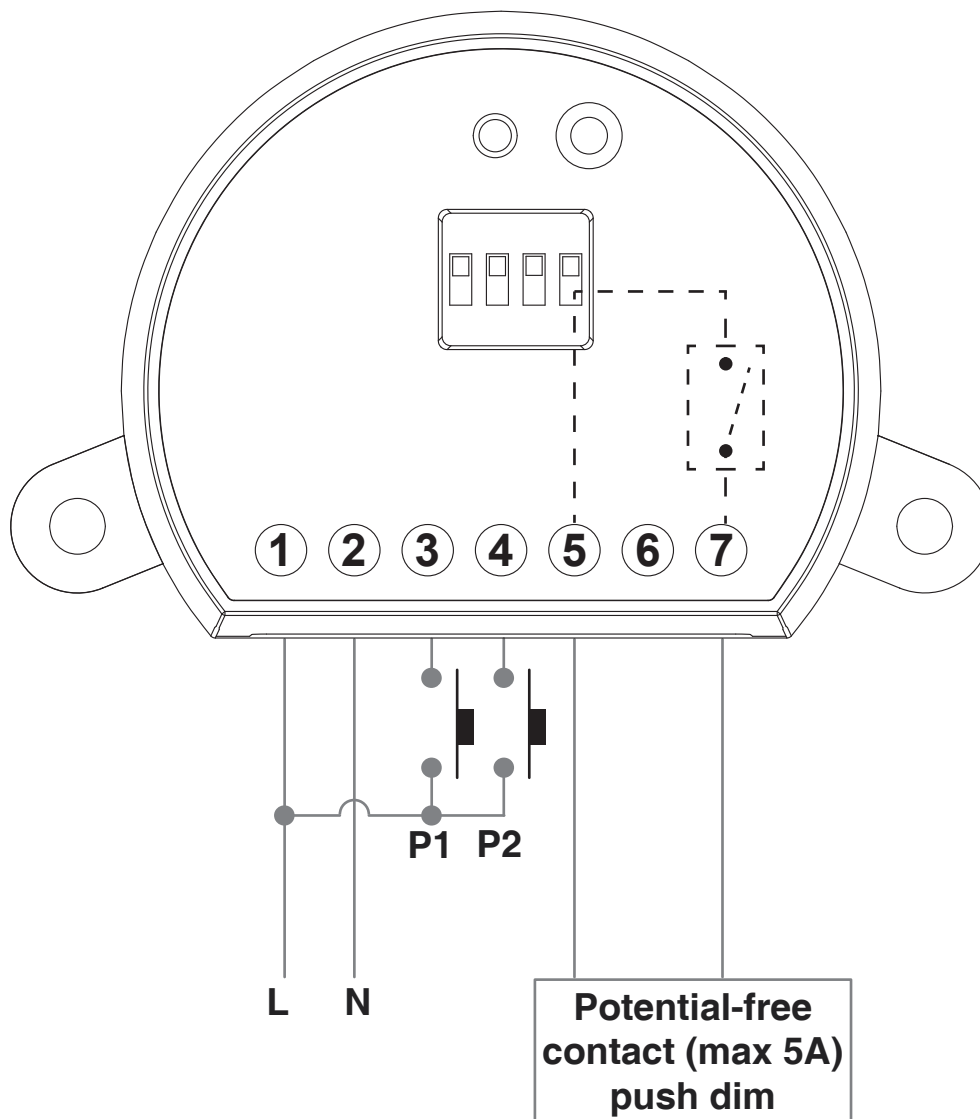

**WARNING:** P1=P2

More loads can be connected by using parallel cabling

## 2.2 INSTALLATION EXAMPLES

The following diagrams are a examples of installation with a driver with a push dim dimmable input.

Fig.2.2a

**ATTENTION:** see the manual of the driver in order to verify the compatibility with standard push button for dimming.  
mcu-push control unit must be connected instead of the wired button, connecting the wires on terminals 6 and 7

### EXAMPLE OF CONNECTION DRIVER TYPE 1

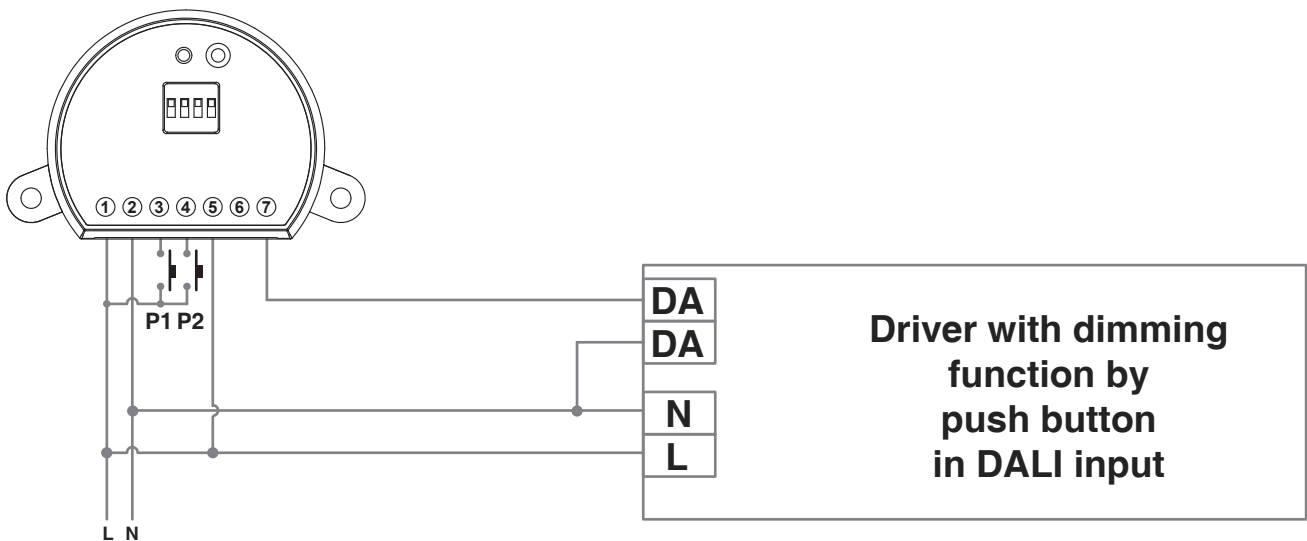

### EXAMPLE OF CONNECTION DRIVER TYPE 2

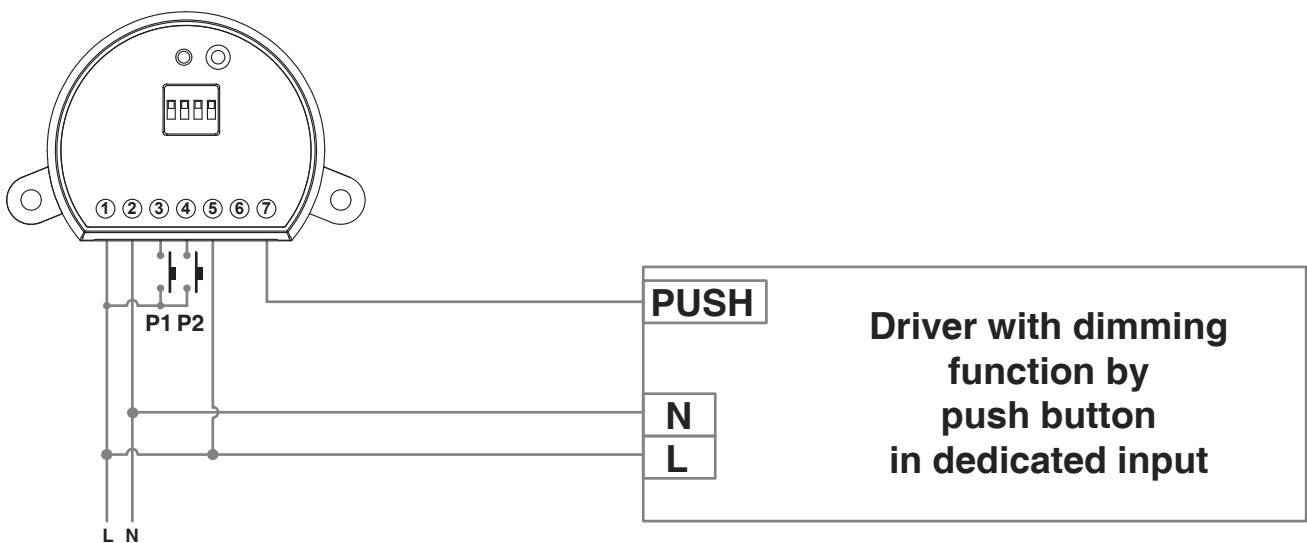

## 3 USE OF THE CONTROL UNIT

### 3.1 USE VIA RADIO

To control the loads via radio you must have compatible transmitters and therefore must carry out the association procedure, see paragraph 4.

If the transmitter is of a generic type, its operation is:

Button of the transmitter	Action of the control unit
<input type="checkbox"/> Short press	Close and reopen the contact
<input type="checkbox"/> Long press	Holds close the contact until the release of the button

If the transmitter is multifunctional type, its operation is:

Button of the transmitter	Action of the control unit
<input type="checkbox"/> Short press	Close and reopen the contact
<input type="checkbox"/> Long press	Holds close the contact until the release of the button
▲	No action
▼	No action

---

### 3.2 USE VIA WIRE

The device is set up to accept commands via wire by button in terminals 3 and 4.

Should you want to control the load only via radio, it is not necessary to connect these devices for the control unit to work properly.

The behaviour of the different keys is shown in the following table:

Input (P1=P2)	Action of the control unit
Short press	Close and reopen the contact
Long press	Holds close the contact until the release of the button

# 4 - RADIO PROGRAMMING

## 4.1 RADIO PROGRAMMING OF MULTIFUNCTIONAL AND GENERIC TRANSMITTERS

This procedure lets you programme only compatible multifunctional transmitters (see table 4.1a) or generic (see table 4.1b) transmitters.

**Tab. 4.1a**

COMPATIBLE MULTIFUNCTIONAL TRANSMITTERS
HB70-SLCT, HB70-SPCT, HB80-1C, HB80-1DIM, HB80-2L, HB80-30D, HB80-30RGBW, HB80-4C, HB80-4DIM, HB80-4L, HB90-6LT, ROUND-1SP SENSA-M, SENSA-P, SENSA-R35M, SENSA-R35P, SENSA-R35T, SENSA-T, TOUCH-1, TOUCH-1CCT, TOUCH-1DIM, TOUCH-1SP, TOUCH-1L , TOUCH-1RGBW, TOUCH-3C, TOUCH-4DIM, TOUCH-CFU

**Tab. 4.1b**

COMPATIBLE GENERIC TRANSMITTERS (WIRELESS BUS)
HB80-6G, MCU-TX4, TOUCH-1G, TOUCH-2G, TOUCH-4G, TOUCH-LOCK4, TOUCH-TX2, ROUND-1G

### PROCEDURE:

- 1- Press the button on the receiver for a short time. The LED comes on and stays on.
- 2- Make a transmission with the remote control to be saved (see transmitter manual, the paragraph entitled "transmitter programming"). The LED on the receiver flashes 3 times to signal that it has been received.
- 3- The control unit listens for 30 seconds  
(to immediately exit the procedure pressthe button on the receiver).

---

## 4.2 DELETION OF TRANSMITTERS

These procedures let you delete from the memory transmitters that have already been programmed.

### DELETION OF SINGLE TRANSMITTER:

- 1- Hold the receiver button down for 8 seconds. The LED begins to flash.
- 2- Make a transmission with the transmitter that you want to delete. The LED flashes quickly and turns off.

### DELETION OF ALL THE SAVED TRANSMITTERS:

- 1- Hold the receiver button down for 8 seconds. The LED begins to flash.
- 2- Press the button on the receiver for a short time. The LED starts flashing quickly and turns off.



MNLMCU-PUSHENV2.0

**Nexta Tech**

company brand of Team srl  
via G.Oberdan 90, 33074  
Fontanafredda (PN) - Italy  
Ph. +39 0434 998682  
Email: [info@nexta-tech.com](mailto:info@nexta-tech.com)  
Web: [www.nexta-tech.com](http://www.nexta-tech.com)